

DEKS

DEKTITE

PRODUCT CATALOGUE



DEKS

EASY TO

WORK WITH

CONTENTS

Design Features	04
Selection Guide	05
Dektite Premium	06
Dektite High Pitch	08
Dektite Combo	09
Dektite Combo Square	10
Dektite Solar	11
Dektite Aluminium	12
Dektite Retrofit	13
Dektite Soaker	15
Dektite Shingle Retrofit	17
Dektite Tophat	18
Acrylead Tile Flash	19
Deks Rapid Flash	20
DEKS Fast Flash	21
Dekstrip	22
DEKS Washers	24
Prosil10	28
Helpful Hints	29
E2/AS1 NZ Building Code	30

DESIGN FEATURES



Flexible Cone Sleeve

Dektites cone shape eliminates seal breakdown due to vibration or expansion and contraction, while isolation of the pipe from the sheeting dampens noise levels.

Stress Isolation Points

Unique to Dektite, two flexible shoulders absorb distortion and stop the transfer of stresses from base to cone as the unit is formed over roofing profile.

Bonded Aluminium Flange

Corrosion resistant, malleable flange evenly distributes fastening pressure and allows ease of hand shaping to most sheet profiles.

Integrity of Flashing Shape

Minimal distortion after installation maintains the natural flashing shape and seals around pipes, while water run-off is improved.

UV Protection

Dektite products are resistant to ultraviolet light damage and will remain fully flexible under all conditions.

Easily Identified Sizing

Pipe diameter rings are clearly marked on the cone sleeve (metric and imperial) for cutting to match the appropriate pipe diameter.

Low Profile Design

Sleek, unobtrusive shape is designed to minimise silhouettes on the roofline, while managing to provide generous internal clearance for steep, angular installations.

Improved Waterproofing

Designed to strengthen sealant bond and improve waterproofing, the ribbed base also has a tapered edge to improve run off and contribute to a superior waterproof seal.

Perfect For Approved Flues!

Dektite polymer flashings have been officially tested and conforms to all Australian and New Zealand Standards on approved flue systems.

EPDM withstands temperatures from -50°C to 115°C and up to 150°C intermittently.

Silicone withstands temperatures from -60°C to 200°C and up to 250°C intermittently.

SELECTION GUIDE

Product	Pg#	Pipe OD (mm)	Slide over	Wrap around	High temp	Cables	Roof type
Dektite Premium	08	0-508	●				Longrun steel roofing & wall cladding
Dektite Combo	10	5-750	●	●			
Dektite Combo Square	11	20-125	●	●			
Dektite Solar	12	0-55	●			●	
Dektite Solar Multicable	12	12x 4-8				●	
Dektite Retrofit	14	20-255		●			
Dektite Soaker	16	75-470	●				
Dektite Premium Red Silicone	08	50-508	●		●		
Dektite Premium Solar Red Silicone	12	0-55	●		●	●	
Dektite Retrofit Red Silicone	14	20-255		●	●		
Deks Dekstrip	26			●			Longrun steel roofing, concrete, clay tile, pressed metal/ decramastic tiles
Fast Flash	25			●			
Dektite Aluminium	13	12-450	●				Concrete, clay tile & pressed metal/ decramastic tiles
Rapid Flash	24	5-330	●				Concrete, clay tile & asphalt shingle
Acrylead Tile Flash	23	0-300	●				
Dektite Shingle Retrofit	21	0-150	●	●			

Key:

Slide over - Dektite slides over the top of the pipe.

Wrap around - Dektite fits around existing or difficult to access pipes.

DEKTITE PREMIUM

Dektite Premium is a versatile flashing design suitable for most pipe flashing requirements.

- Suitable for longrun steel roofing & wall cladding
- EPDM temperature range: -50°C to 115°C and up to 150°C intermittently
- Silicone temperature range: -60°C to 200°C and up to 250°C intermittently



Code: Black EPDM	Code: Grey EPDM	Code: Red Silicone	Pipe OD (mm)	Base (mm)	Roof Pitch
DFE10MB	DFE10MG		0-20	71 x 71	Up to 60°
DFE100B	DFE100G		0-35	101 x 101	
DFE101B	DFE101G	DFE201RE	5-55	139 x 139	Up to 45°
DFE102BA	DFE102GA	DFE202REA	50-70	181 x 181	
DFE103B	DFE103G	DFE203RE	5-127	220 x 220	
DFE104B	DFE104G	DFE204RE	75-175	280 x 280	
DFE105B	DFE105G	DFE205RE	100-200	308 x 308	
DFE106B	DFE106G	DFE206RE	125-230	363 x 363	
DFE107B	DFE107G	DFE207RE	150-300	456 x 456	
DFE108B	DFE108G	DFE208RE	170-355	496 x 496	
DFE109B	DFE109G	DFE209RE	230-508	681 x 681	

Depending on penetration size, roofing profile and pitch, additional flashings may be required for New Zealand Building Code requirements. See pg 31 & 32.

DEKTITE PREMIUM (CONT.)

Installation instructions

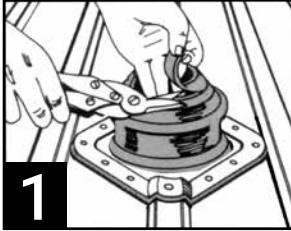

Trim the cone to suit pipe size using sharp tin snips.

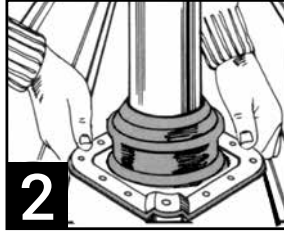

Slide down the pipe using water as a lubricant.

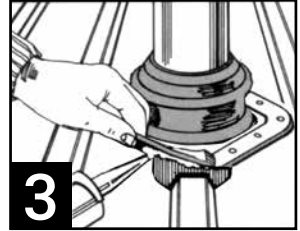

Apply a neutral cure 100% silicone sealant to the underside of the Dektite.

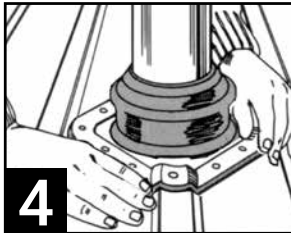

Press base to roof profile by hand.

Don't fully extend, this allows for vibration.

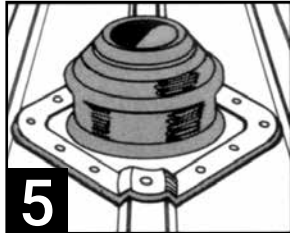

Fit the Dektite on the diamond or bias.

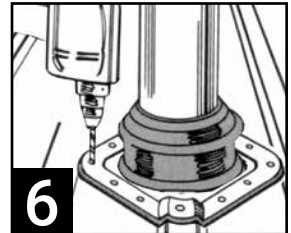

Fasten using self drilling washered screws or sealed rivets.

Fit fasteners progressively outward in opposing pairs.

DEKTITE HIGH PITCH

The Dektite High Pitch is designed on a 40 degree pitch providing a water tight seal on roof pitches from 35 to 60 degrees.

- Flashing penetrations 0 - 159mm in black EPDM
- EPDM withstands temperatures from -50°C to 115°C and up to 150°C intermittently.



Code: Black EPDM	Pipe OD (mm)	Base (mm)	Roof Pitch
DFH103B	0-159	280 X 280	35° - 65°

Depending on penetration size, roofing profile and pitch, additional flashings may be required for New Zealand Building Code requirements. See pg 31 &32.

DEKTITE COMBO

Dektite Combo flashes over or around existing or difficult to access pipes using provided crimps.

- Suitable for longrun steel roofing & wall cladding
- For both standard and retrofit applications
- Clear markings for easy cutting to pipe size
- For pipe sizes from 5 - 750mm
- Available in black EPDM
- Withstands temperatures from -50°C to 115°C and up to 150°C intermittently
- Clips included



Code: Black EPDM	Description	Pipe OD (mm)	Base (mm)	Roof Pitch
DC101BC	Dektite Combo #1	5-60	141 x 141	Up to 40°
DC102BC	Dektite Combo #2	45-85	181 x 181	
DC103BC	Dektite Combo #3	5-127	221 x 221	
DC104BC	Dektite Combo #4	75-175	287 x 287	
DC105BC	Dektite Combo #5	108-190	368 x 368	
DC106BC	Dektite Combo #6	125-230	368 x 368	
DC107BC	Dektite Combo #7	150-280	456 x 456	
DC108BC	Dektite Combo #8	175-330	456 x 456	
DC109BC	Dektite Combo #9	240-508	707 x 707	
DC110BC	Dektite Combo #10	400-750	1017 X 1067	

Depending on penetration size, roofing profile and pitch, additional flashings may be required for New Zealand Building Code requirements. See pg 31 & 32.

DEKTITE COMBO SQUARE

Dektite Combo Square flashes over or around existing or difficult to access pipes using provided crimps.

- Suitable for longrun steel roofing & wall cladding
- For both standard and retrofit applications
- Clear markings for easy cutting to pipe size
- Available in black EPDM
- Withstands temperatures from -50°C to 115°C and up to 150°C intermittently
- Clips included



Code: Black EPDM	Description	Pipe OD (mm)	Base (mm)	Roof Pitch
DCS103BC	Dektite Combo Square	20-125	221 x 221	Up to 40°

Installation instructions

1. Trim cone to suit pipe size, cut seam and aluminium base using sharp tin snips.
2. Apply a bead of neutral cure 100% silicone sealant to one side of the cut seam.
3. With seam in downstream position, wrap cone around pipe and engage 1st clip at top of seam using multigrips.
4. Engage remaining clips working down from top of cone to base. Don't over crimp.
5. Apply bead of neutral cure 100% silicone sealant to underside of Dektite Combo. Shape to roof by hand.
6. Screw down using self drilling washered screws or sealed rivets.
7. Fasten down by placing a fastener either side of seam first then secure rest of base working outwards in opposing pairs.
8. Apply sealant to top of base closure and any other potential leak areas.

Depending on penetration size, roofing profile and pitch, additional flashings may be required for New Zealand Building Code requirements. See pg 31 & 32.

DEKTITE SOLAR

Dektite Solar is perfect for flashing pipes and cables on steel roofing & wall cladding.

- Square base fits most roof profiles
- Edged with flexible aluminium flange
- Available in highly durable black EPDM or red silicone
- Suitable for pipes and cables

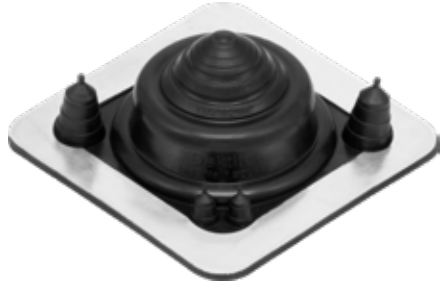

Code: Black EPDM	Code: Red Silicone	Pipe OD (mm)	Roof Pitch
DFE100BS	DFE200RES	0 - 35	Up to 45°
DFE101BS	DFE201RES	5-55	

DEKTITE SOLAR MULTICABLE

Dektite Solar Multicable is perfect for flashing pipes and cables on steel roofing & wall cladding.

- Incorporates 12 cable nipples
- Ideal for solar PV installations
- Black EPDM high UV resistant cone



Code	Description	Pipe OD (mm)	Roof Pitch
DFE101BM	MULTI CABLE	12x 4-8	Up to 45°

Depending on penetration size, roofing profile and pitch, additional flashings may be required for New Zealand Building Code requirements. See pg 31 & 32.

DEKTITE ALUMINIUM

Dektite Aluminium is the best solution for Pressed Metal & Decramastic tiles.

- 99.9% pure grade aluminium base
- Strong, malleable and easy to install
- No lead run off
- Ideal for potable water collection
- Withstands temperatures from -50°C to 115°C and up to 150°C intermittently



Code	Pipe OD (mm)	Base (mm)	Roof Pitch
TFA12-70	12-70	500 x 600	Up to 45°
TFA50-170	50-170	500 x 600	
TFA110-200	110-200	600 x 600	
TFA160-300	160-300	764 x 764	
TFA300-450	300-450	956 x 956	

Installation instructions

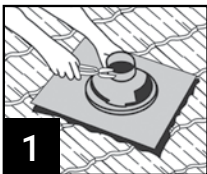

1 Trim Dektite cone to suit pipe size using sharp tin snips.

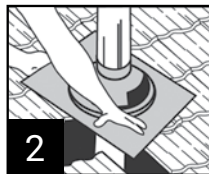

2 Lubricate flue with water, slide Dektite down to the tile level.

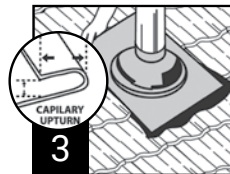

3 Form an anti-capillary fold. Place upper edge of base under up-stream tiles.

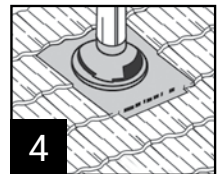

4 Dress base to profile. Cut tabs on the bottom corners and fold under to stop wind lift.

DEKTITE RETROFIT

Dektite Retrofit flashes over or around existing or difficult to access pipes with built in crimps. Snaps together without the need for loose crimps.

- Wraps around existing pipes
- Snaps together in seconds with built in crimps
- Aluminium base for easy profile moulding
- EPDM: temperature range from -50°C to 115°C and up to 150°C intermittently
- Silicone: temperature range from -60°C to 200°C and up to 250°C intermittently



Code: Black EPDM	Code: Grey EPDM	Code: Red Silicone	Pipe OD (mm)	Base (mm)	Roof Pitch
RF801B	RF801G	RF901	20-70	160	Up to 40°
RF802B	RF802G	RF902	50-185	273	
RF803B	RF803G	RF903	85-255	369	



Depending on penetration size, roofing profile and pitch, additional flashings may be required for New Zealand Building Code requirements. See pg 31 & 32.

DEKTITE RETROFIT (CONT.)

Installation instructions

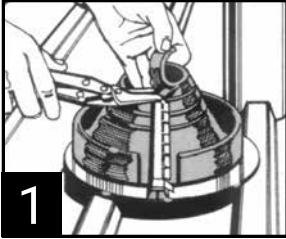

1 Measure pipe diameter and trim cone.

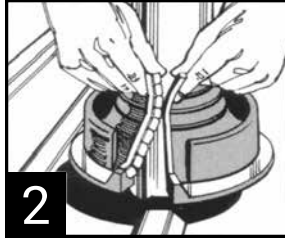

2 With clip in down-stream position, tension top of cone around pipe and engage metal teeth in opposing pockets.

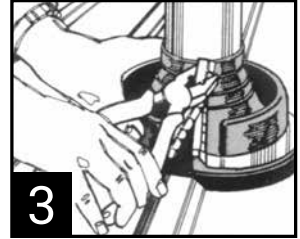

3 To assist in locating clip into pocket, place hand behind the seam.
Fasten clip with pliers or multi-grips, working from top to base.

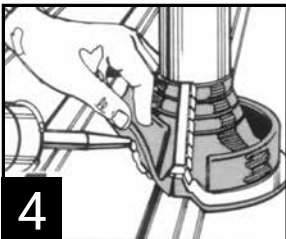

4 Press the Dektite base to contour of roof profile.
Apply bead of neutral cure 100% silicone sealant to the underside.

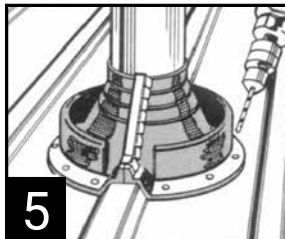

5 Fasten flashing with washered self drilling screws.
As per diagram, secure clip by placing a fastener either side of the clip first.

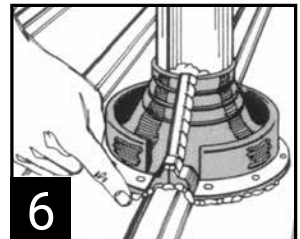

6 Apply sealant to top of crimp closure and any other potential leak areas.

DEKTITE SOAKER

The Dektite Soaker reduces and diverts rainwater backup on very low or very high roof pitches or deep ribbed roofing profiles.

- Engineered to eliminate damming
- Withstands temperatures from -50°C to 115°C and up to 150°C intermittently



Code: Black EPDM	Pipe OD (mm)	Base (mm)	Roof Pitch	Pipe (mm)	Roof Pitch
DF602	75 - 160	410 x 360	10° to 60°	N/A	N/A
DF603	114 - 165	485 x 460	10° to 60°	165 - 255	10° to 40°
DF605	250 - 358	708 x 635	10° to 60°	358 - 410	

For any pitch above 40°, do not cut below the first three sizing ribs on 603, 605 or 606.

The Dektite Soaker is an Alternative Solution to NZBC E2/AS1. Council consent must be sought before installation.

DEKTITE SOAKER (CONT.)

Installation instructions



1 Trim cone to suit pipe size using a sharp pair of tin snips.

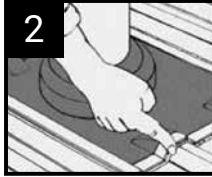

2 Lubricate pipe with water.
Slide the soaker flashing down the pipe and form to suit the roof profile.

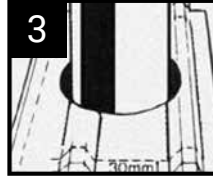

3 Mark the outline of the soaker on the roof then remove.
Mark a lap allowance of 30mm (inside the original mark).
Now determine where soaker sides will finish.



4 Remove roof inside 30mm line.
Trim sharp/uneven edges.
Install timber supports to brace roof where ribs have been removed.
(Pipe not shown above for clarity)



5 Replace soaker in position and apply silicone sealant to the roof while holding up the edge of the flashing.

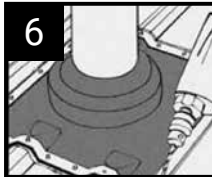

6 Fix using washered self drilling screws or sealed rivets to the middle front and middle back of the soaker and fix progressively towards the edge.

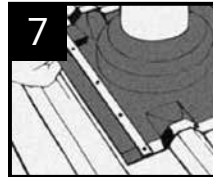

7 Fasten the provided strips.
Trim excess soaker where necessary.
Note:
Side trimming of the soaker should be determined prior to cutting the roof.

DEKTITE SHINGLE RETROFIT

For asphalt shingle roof retrofit applications on electrical masts, re-roofing etc.

- Available in black, made from proprietary polymer material compatible with asphalt shingles
- Slide down the pipe without cutting, or cut along the zipper and use the clips supplied for retrofitting
- Aluminum flange nails securely to the roof



Code	Pipe OD (mm)	Base (mm)	Roof Pitch
DSR103B	0 - 135	380 x 380	Up to 45°

DEKTITE TOPHAT KIT

Dektite Tophat Kit is a multi pipe penetration kit with all required components to get the job complete.

For use with air conditioning units, refrigeration and heat pump pipe work, electrical cables, solar panels, etc.

Kit includes:

- PVC cap
- PVC slotted pipe
- Dektite Premium
- Cable tie
- Hex head screws



Code	Pipe OD (mm)	Clearance Diameter (mm)
RFPN 65	65	65
RFPN80SC	80	76
RFPN110FC	110	103

Parts & installation

See page 07 for Dektite Premium installation instructions.



Top Hat



Pipe



Dektite Premium

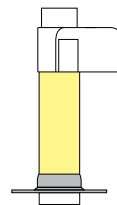

Assembled

Depending on penetration size, roofing profile and pitch, additional flashings may be required for New Zealand Building Code requirements. See pg 31 & 32.

ACRYLEAD TILE FLASH



Acrylead Tile Flash has a thermo baked acrylic primer coating, ready for finish coating to match surrounding colours.

- Best option for concrete/clay tile roofs
- Complies with AS1804 and has a minimum unit mass of 17kg/m²
- Withstands temperatures from -50°C to 115°C and up to 150°C intermittently
- Not for use with zinc/aluminium coated pressed metal tiles or steel roofing



Code	Pipe OD (mm)	Base (mm)	Roof Pitch
TFL0-35	0-35	300 x 600	Up to 45°
TFL0-35TWIN	0-35 x 2	300 x 600	
TFL5-55	5-55	300 x 600	
TFL50-70	50-70	300 x 600	
TFL5-127	5-127	400 x 600	
TFL75-175	75-175	450 x 600	
TFL150-300	150-300	600 x 900	



DEKS RAPID FLASH

Rapid Flash is a 100% Lead-Free and flexible flashing. Easy to shape for all tile roofs that have a pipe penetration.

- Rubber reinforced aluminium mesh
- Easy to apply and shape
- Fully adhesive base
- UV Rated
- Withstand temperatures of -50°C to 115°C and up to 150°C intermittently



Code: Grey EPDM	Pipe OD (mm)	Apron Size (mm)	Roof Pitch
DRF101GB	5-127	370 x 560	Up to 40°
DRF103GB	50-170	370 x 560	
DRF108GB	175-330	560 x 850	

Installation instructions

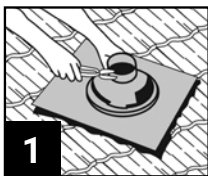

Trim RapidFlash to suit pipe size using sharp tin snips.

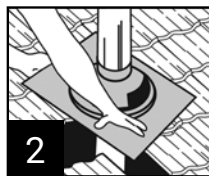

After lubricating the flue with water, slide RapidFlash down to the tile level.
Ensure tile surface is clean, dry and free from debris.

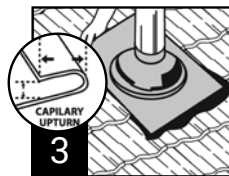

Form an anti-capillary fold then place upper edge of base under up-stream tiles.

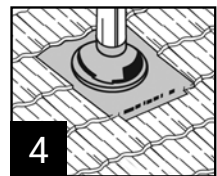

Dress base to profile.

DEKS FAST FLASH

Fast Flash is a self adhering Lead-Free flash strip and is ideal for a quick and secure flashing solution.

- Light weight, easy to trim and fully self-adhesive
- Slow set adhesive allows time for repositioning
- Flexible, malleable and expandable
- Environmentally friendly aluminium stretch netting
- Compatible with zinc/aluminium coated steel



Code: Grey	Length (M)	Width (mm)	Weight (KG)
FFR5-280G	5	280	4.7
FFR5-370G	5	370	5.9
FFR5-560G	5	560	9.2

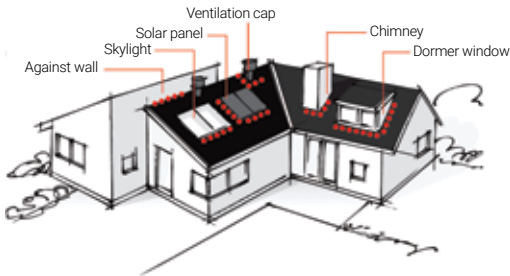

DEKSTRIP FLASHING

Dekstrip stretches and forms around most roof profiles, with its concertina edge it can stretch up to 25% making Dekstrip flexible and ideal for a wide range of flashing applications.

- Contains a totally encased expanding aluminium strip
- Can be stretched and formed around most roof profiles
- EPDM withstand temperatures from -50°C to 115°C and up to 150°C intermittently
- Ideal for expansion joints or joining box guttering



Code	Material	Length (m)	Width (mm)
DS3-235	Rubber (TPE) Thermoplastic Electomer	3.1	235
DS10-180		10	180
DS10-235		10	235
DS10-305		10	305
DS23-180		23	180
DS23-235		23	235
DS23-305		23	305
DS23-450		15	450

DEKSTRIP FLASHING (CONT.)

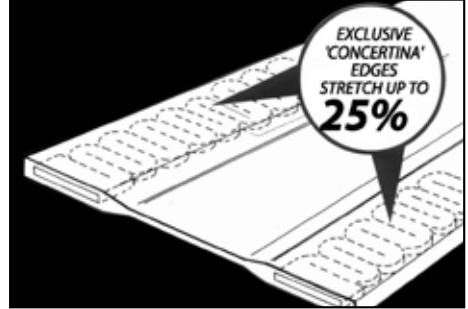
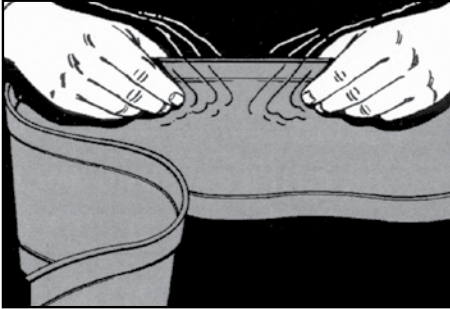

Installation instructions

1. Mark a line on the pipe, 156mm above the roof. Take this mark from the valley. Circle the pipe.
2. Fasten Dekstrip at this line, after applying neutral cure 100% silicone sealant. Overlap ends by 50mm.
3. Stretch the entire unfastened bottom edge.
4. Seal and fasten bottom edge, allowing same overlap at bottom as at top - suggest valley fixing.

All listed measurements are for 235mm wide strip flash.

If using other widths use a ratio of 2/3 up the pipe 1/3 over the roof profile.

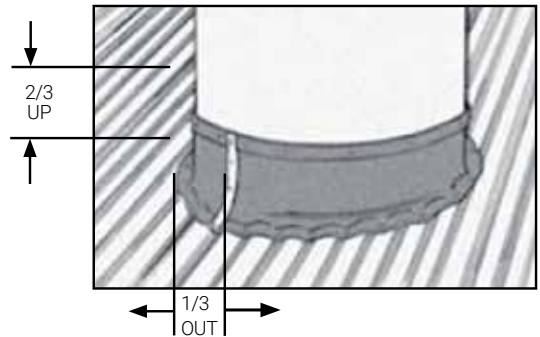

DEKS WASHERS - MULTISEAL

Deks Multiseal range of washers are ideal for metal roof applications that require high strength, Uv, Ozone and corrosion resistance.

- An EPDM encapsulated metal face for extra strength
- Engineered load distribution to minimise distortion
- Corrosion resistance with aluminium backed washers

The washer has been designed to seal in four locations, offering ultimate sealing and protection.

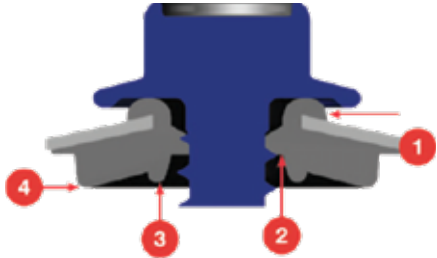

Code	Fastener Gauge	Outside Diameter (mm)	Box Qty
DM-A16-B12-A	#12	16	15000
DM-A19-B14-A	#14	19	10000
DM-A25-B14-A	#14	25	5000

DEKS WASHERS - CYCLONIC

Deks Cyclonic washers are ideal for metal roof applications that require high strength, UV, Ozone and corrosion resistance.

- Vibrational loads being designed for cyclonic environments
- Outstanding sealing with rubber profile sealing securely
- High strength with metal profile taking the strain

The washer has been designed to seal in four locations, offering ultimate sealing and protection.



Code	Fastener Gauge	Outside Diameter (mm)	Box Qty
DM-A25-B14-D	#14	25	5000

POLYCARBONATE WASHERS

Polycarbonate grey dome roof washers are engineered for creating a watertight seal between the fastener and the surface.

- Precision engineered for consistent fit and performance
- Watertight and efficient sealing
- UV, Ozone and corrosion resistance



Code	Fastener Gauge	Outside Diameter (mm)	Box Qty
DE-P22-G12-A	#12	22	10000
DE-P26-G12-A	#12	26	5000
DE-P32-G12-A	#12	32	5000

DEKS SPANDEK WASHERS

Spandek roof washers are specially engineered to suit steel roofing profiles.

- Outstanding sealing with rubber profile sealing securely



Code	Fastener Gauge	Outside Diameter (mm)	Box Qty
DE-K29-B14-B	#14	29	5000
DE-S35-B14-A	#14	35	5000

All DEKS washers are non-conductive

Non Conductivity

Threshold Conductivity

Low Conductivity

High Conductivity

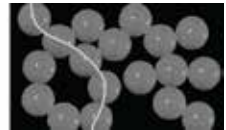
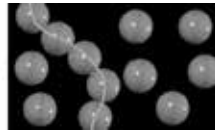

Very low levels of carbon black inhibit performance.

Just enough carbon to be non-conductive with excellent performance.

A little too much carbon creates an electrical pathway.

High density carbon poses a corrosion risk.

PROSIL 10

Prosil 10 Roof & Gutter Silicone provides excellent adhesion and long term reliability.

It reacts with atmospheric moisture to produce a form in place silicone seal.

- Weather and UV Resistant
- 5-8 minute skin time
- Low Slump
- Does not corrode metals
- Movement capability + 25%
- Operating Temperature range of -60°C to 180°C
- AS 4020/ISO 11600 approved



Code	Description	MOQ Box Qty
PROSIL10	100% Neutral Cure Silicone (300ml)	20

Silicone Application for Dektites

For adequate bonding all surfaces must be clean and dry.

1. The base of the Dektite should be moulded by hand to form a snug fit to the roof profile.
2. Apply a continuous bead of neutral cure 100% silicone to the underside of the Dektite.
3. For an effective seal, sandwich a 1-3mm bead of silicone between Dektite and surface.
4. Fit Dektite to sit snugly on the roof profile.
5. Fasten with washered screws/Hex screws (NB: Screw coatings of class 4 or 5 are required), or rivets.
6. Remove excess silicone and collect any swarf.

HELPFUL HINTS

Dektites

- Sharp tin snips will provide the smoothest finish. When cutting do not use a knife
- Always cut where sizes are indicated. Incorrect cutting may result in poor fit
- Hand form aluminium edge before fastening
- Fasten from vertical centre to outside
- When pulling the Dektite down a pipe, lubricate the pipe with water first
- Install on the diamond bias

Retrofit and Combos

- Do not overcrimp seam
- For pipes over 100mm diameter use a stainless steel support clip (hose clamp) if desired

General Points - Applicable to all Deks flashing products

- Always ensure that a liberal amount of neutral cure 100% silicone sealant (roof and gutter approved) is applied UNDER any perimeter aluminium-backed edge
- Seamed pipes: when flashing a metal flue that has an exposed seam, use a neutral cure 100% silicone sealant (roof and gutter approved) to seal the seam from underside of the cowl to the top of Dektite cone
- Where multiple skin flues are used, EPDM Dektites are appropriate
- Under no circumstances should any Dektite product be used on an unapproved (i.e. single skin) flue discharging from a wood combustion appliance
- Overstretching of EPDM compound products can lead to shortened life expectancy
- Please note that the outside temperature of the pipe is usually significantly lower to the exit temperature of the appliance

E2/AS1 NZ BUILDING CODE

E2/AS1 - External Moisture

Summary of New Zealand Building Code clause E2/AS1 External Moisture.

For full details on E2/AS1 NZBC -

<https://www.building.govt.nz/building-code-compliance/e-moisture/e2-external-moisture/>

Fig.29 Pipe penetration for masonry tile

Paragraphs 8.2.7

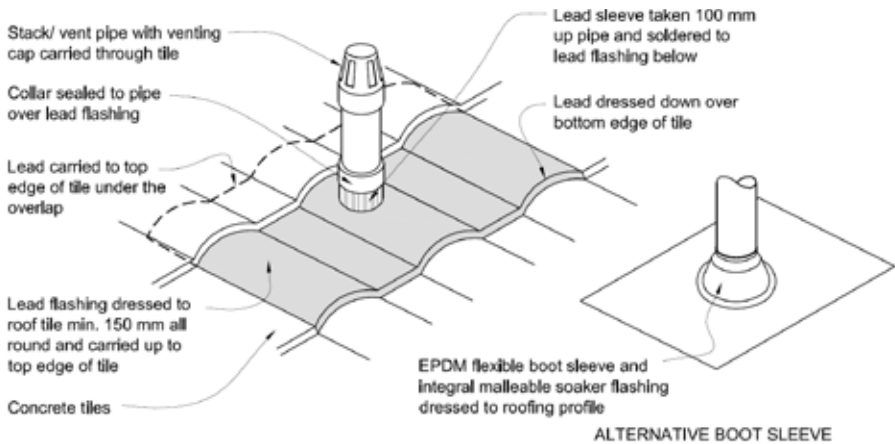

8.2.7 Pipe penetrations for masonry tile

Penetrations shall be flashed as shown in Figure 29 to Figure 31.

Holes in tiles for pipe penetrations shall be machine-cut to minimise the size of the hole.

8.3.10 Roof penetrations

Pipe penetrations shall be flashed using EPDM flashings similar to that shown for masonry tiles, Figure 29.

Use purpose-made preformed rooflights and ventilators supplied by the manufacturer of the tiles where available.

E2/AS1 NZ BUILDING CODE (CONT.)

Fig.53 Flashing for small pipes

Paragraphs 8.3.10, 8.4.17, 9.6.8.5, 9.6.9.6

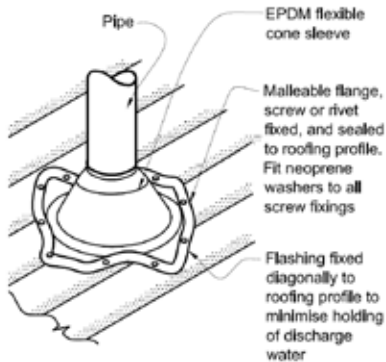

NOTE:

(1) Max. roof pitch for this flashing 45°, minimum pitch 10° if base of flange covers one or more complete troughs.

(2) For pipes up to 85 mm diameter.

8.4.17 Roof penetrations

The maximum length of profiled roof cladding above penetrations shall be as shown in Table 17 (see pg.86 from the E2/AS1).

The edge of roofing penetrations over 200 mm wide shall be supported in either direction with additional framing as shown in Figure 21 (see pg.62 from the E2/AS1).

Roof penetrations shall be flashed as follows:

- a) Pipe penetrations up to 85 mm shall be flashed using an EPDM boot flashing as shown in Figure 53,
- b) Pipe penetrations up to 500 mm shall be flashed using a soaker flashing and EPDM boot flashing as shown in Figure 54,

Penetrations on lower pitched roofs, larger penetrations, or needing specialised complex flashings will require specific design to suit the particular circumstances.

The New Zealand Metal Roof and Wall Cladding Code of Practice should be consulted for guidance.

E2/AS1 NZ BUILDING CODE (CONT.)

Fig.54 Soaker flashing for pipe penetrations

Paragraphs 8.4.17

NOTE: (1) Suitable for pipes from 86 mm to 500 mm diameter.
(2) Suitable only for roof pitches of 10° or more.

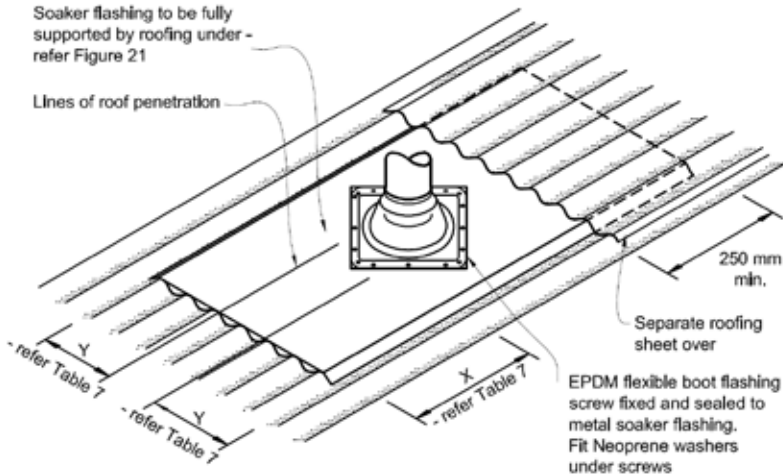

9.6.8.5 Vertical profile: penetrations

Pipe penetrations shall be as per Figure 53.

9.6.9.6 Horizontal profile: penetrations

All services penetrations through claddings shall be flashed and sealed. Pipe penetrations are shown in Figure 53.

NOTES:

STOP LEAK

REPAIR AND SEAL LEAKS INSTANTLY



Easy DIY Application

Permanent Seal

Discreet Repairs

STOP LEAK

All Purpose Weatherproof Repair Tape

Stop Leak tape is a versatile all-purpose weatherproof repair tape for sealing and repairing leaks.

Features:

- Permanent seal
- Easily moulds into place
- Non reflective & paintable grey surface
- Temperature range between 5°C - 40°C

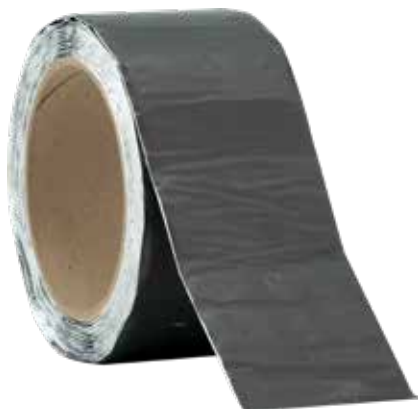

Suitable for:

Roofing, guttering, downpipes, water tanks. Joints around skylights, doors, adjoining building surfaces, Seams in caravans, trucks, sheds, windows, adheres permanently to most surfaces.

Gutters



Seams

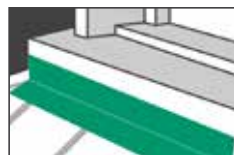

Roofs



Water Tanks



Code	Description	Width	Length	Box Qty
SL50X3	Stop Leak Tape Grey 50mm x 3m	50 mm	3 M	12
SL75X3	Stop Leak Tape Grey 75mm x 3m	75 mm		8
SL50x10	Stop Leak Tape Grey 50mm x 10m	50 mm	10 M	12
SL75X10	Stop Leak Tape Grey 75mm x 10m	75 mm		8
SL100x10	Stop Leak Tape Grey 100mm x 10m	100 mm		6
SL150x10	Stop Leak Tape Grey 150mm x 10m	150 mm		4

Our range of DEKS flashing systems ensures a weathertight seal for any building and construction flashing requirements.



Proudly Supplied by



DLM WALLACE
KIWI INGENUITY SINCE 1884



www.dlmwallace.co.nz